

Wideband Data Transmission Experiment in the Deep Ocean

Hiroshi Ochi, Yoshitaka Watanabe and Takuya Shimura

Japan Agency for Marine-Earth Science and Technology, 2-15 Natsushima-cyo, Yokosuka, Japan, {ochi, yoshitakaw, shimurat}@jamstec.go.jp

In order to control a remotely operated vehicle, we have been studying about a high-speed acoustic communication. To widen a bandwidth of communication, a wideband transducer was made. The carrier frequency of the modulated acoustic signal is 80 kHz, and bandwidth is 20 kHz. By using this transducer, a vertical data transmission experiment was carried out at deep-sea area. Transmission range was 100 m, modulation method was 16-quadrature amplitude modulation (QAM). The transmission rates in the experiment were 10 k symbol per second (sps), 12.5 kbps, 16 kbps and 20 kbps. A demodulation performance was better than the symbol error rate of 10^{-4} order in each transmission rate. In general, it is said that this performance is enough to transmit the image. Even though it was a very stable characteristic of a communication channel, a high-speed acoustic data transmission experiment up to 80 kbps was carried out at the real sea.

1 Introduction

There are many research of underwater acoustic communication [1, 2]. In Japan Agency for Marine-Earth Science and Technology (JAMSTEC), we have been studying the underwater acoustic communication. Its research is focused on a research of equipments using in the deep-sea. We have developed some acoustic data transmission systems for 4,000-7,000 m range. One is called that the acoustic colour image transmission system for manned submergence vehicle "SHINKAI 6500" [3], which can be transmitted colour still image in 16 kbps. Another one is called that the acoustic data transmission system for AUV "URAHSIMA" [4], which can be transmitted colour still image in 32 kbps. Both of the systems are using 20 kHz as a carrier frequency.

We are now studying about a short range (a few hundred meters) and a high-speed acoustic communication. The aim of that study is to control the remotely operated vehicle (ROV) using acoustic signal. For extending a bandwidth, 80 kHz was selected as a carrier frequency, and the newly developed transducer has had 20 kHz of bandwidth. A basic experiment of wideband acoustic communication was carried out in the deep sea, using 16-QAM modulation method. Carrier frequency is 80 kHz, transmission rate is up to 80 kbps. In this paper, the results of the sea trial in the deep sea are described.

2 Transmitter

The transmitter is shown in Figure 1. This transmitter is composed of a conical beam transducer, digital-to-analogue converter (DAC), a power amplifier, a personal computer (PC) with hard disk drive and a temperature-depth sensor (TD-sensor). Modulated signals have stored in the hard disk drive beforehand.

And signals are transmitted from the transducer, which is controlled by a timer unit. Carrier frequency is 80 kHz, and bandwidth is 20 kHz.

2.1 Modulation Method

16-quadrature amplitude modulation (16-QAM) was applied as a modulation method. 16-QAM signal $s(t)$ is represented as Equation 1.

$$s(t) = a \cos(\omega t + \theta) + b \sin(\omega t + \theta) \quad (1)$$

In Equation 1, a and b are coefficients of in-phase component and quadrature-phase component respectively. ω is angular frequency of carrier frequency. θ is a phase of each symbol. The constellation of 16-QAM is shown in Figure 2.

Transmitted data packet format is assigned as shown in Figure 3. At first, a channel probe pulse is transmitted for measuring a channel response. This pulse is a chirp pulse, which is swept from 100 kHz to 60 kHz. In this experiment, a channel probe is not used for a demodulation. After one second of silence, a start code is transmitted, which is used for detecting a start point.

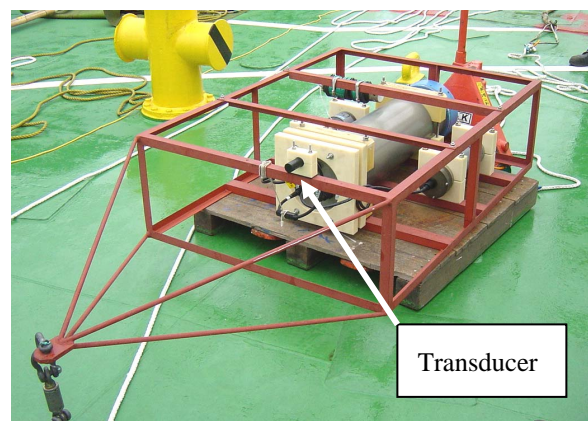

Figure 1: An outlook of the transmitter.

Training sequence is composed of 200 symbols of (1,13) random sequence and 1024 symbols of 16-number pseudo-random sequence. Finally, a data block is transmitted. The data block consists of 15,033 symbols of 16-number pseudo-random sequence.

2.2 Transducer

For this sea trial, the wideband transducer was developed. It is made from piezo composite materials. The shape of this transducer is 10 cm long and 3 cm diameters. The directivity pattern of this transducer is shown in Figure 4, and the transmitting voltage response (TVR) is shown in Figure 5.

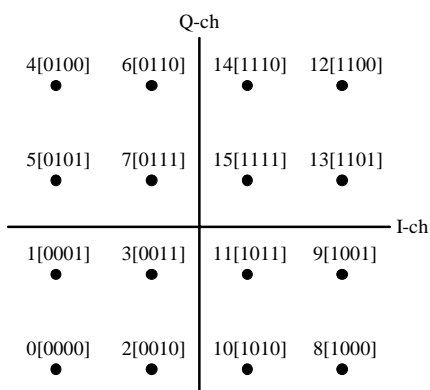

Figure 2: Constellation of 16-QAM.

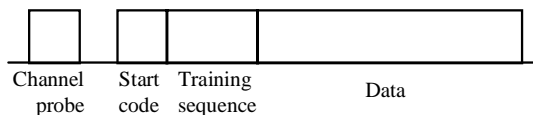

Figure 3: Data packet format.

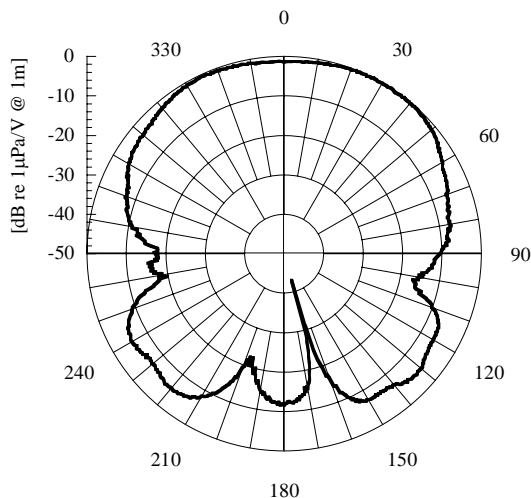

Figure 4: Directivity pattern of the transducer.

3 Receiver

The receiver is shown in Figure 6. This receiver is composed of two omni-directional hydrophones, analogue-to-digital converter (ADC), two pre-amplifiers, two band-pass filters, a PC, a TD-sensor and an acoustic transponder.

Transmitted signals, which received by two hydrophones, are sampled at 800 kHz by the ADC and stored in the hard disk drive in the PC. A demodulation is processed after recovering by software.

3.1 Demodulator

The block diagram of the demodulator is shown in Figure 7. This demodulator is called a multi-channel adaptive decision feedback equalizer (DFE) receiver [5]. In this sea trial, two hydrophones were used. So, affixing character *K* in Figure 7 becomes 2. The least

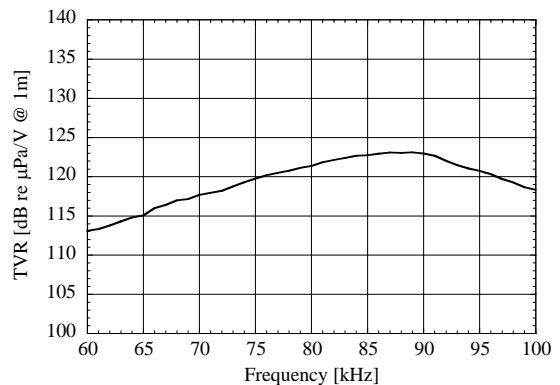

Figure 5: Transmitting voltage response of the transducer.



Figure 6: The receiver.

mean square (LMS) algorithm was applied to an adaptive algorithm for updating filter parameters. Second order digital phase lock loops (DPLLs) were applied to a phase compensation unit.

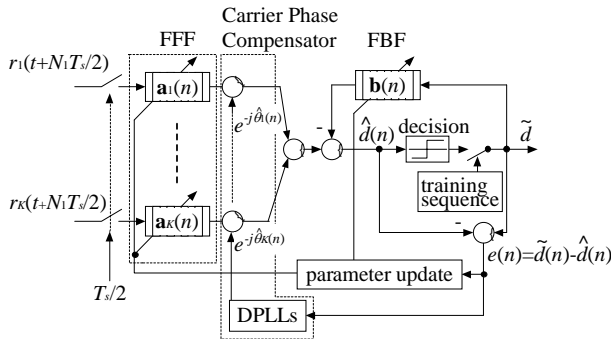

Figure 7: Block diagram of a multi-channel DFE receiver.

4 Experiment

An experiment was carried out at approximately 1,300 m depth area. Figure 8 shows the arrangement of the sea trial. The transmitter and the receiver were both suspended from the surface ship in a same line. The transmission ranges was 91 m. Depth of the transmitter and of the receiver were very stable, because sea surface was very calm. Several data of different SNR were taken by changing a source power level of the transmitter. And different symbol rate data (10k, 12.5k 16k and 20ksps) are taken also.

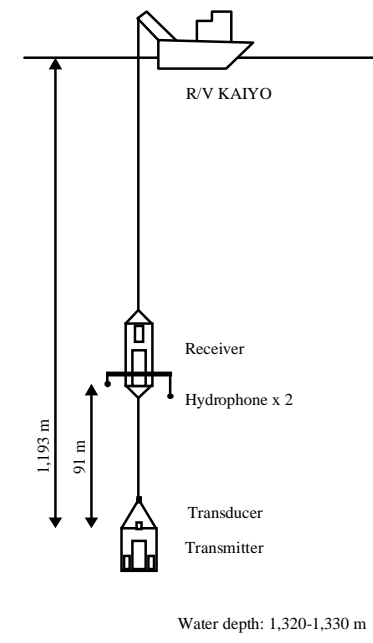

Figure 8: The arrangement of the sea trial.

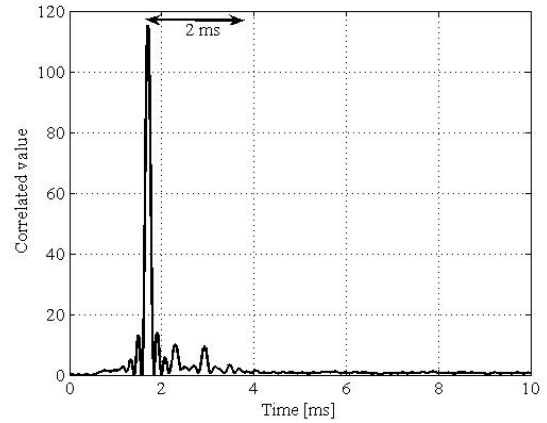
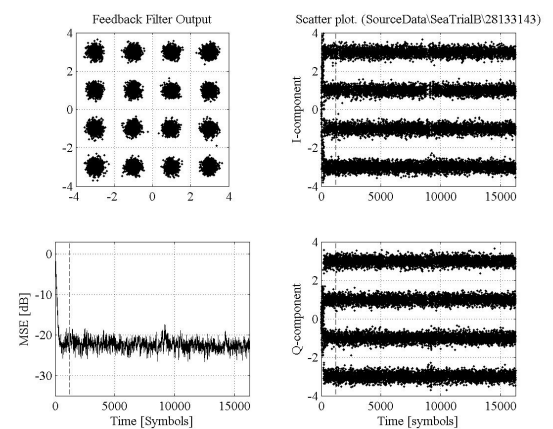
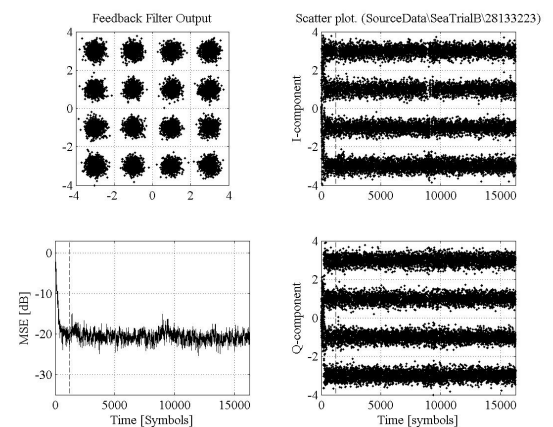

Figure 9: Channel response.



(a) Symbol rate = 16 kpsps. SNR = 22.6 dB



(b) Symbol rate = 20 kpsps. SNR = 22.5 dB

Figure 10: Examples of demodulation. (In (a) and (b), upper left: scatter plot in decision oriented mode, upper right: I-component vs. time, lower right: Q-component vs. time, lower left: mean square error vs. time.)

Channel response is shown in Figure 9. Time spread is estimated approximately 2 ms.

Figure 10 shows examples of the results of the demodulation. Figure 10 (a) shows the result of the case of 16 ksps of symbol rate. And (b) shows the result of the case of 20 ksps of symbol rate. In both of the examples, no error occurred. From mean square error (MSE) property (lower left subplot), it can be seen that the adaptive DFE is well converged while in the training mode.

Symbol error rate vs. input SNR characteristics is shown in Figure 11. 30 packets were processed in each symbol rate. In case of error free, the point is plotted as 10^{-5} . In this experiment, the range of input SNR is high. So, at the almost of the received data, error free communications were carried out. The solid line in Figure 11 is shown the calculated value, which is assuming the additive white Gaussian noise (AWGN) as the noise. To precise estimate of the communication range, data of around 20 dB of input SNR are needed. But it can be said that the roughly estimated communication range is 300 m. Because this system has approximately 10 dB of margin, when transmission power is maximum.

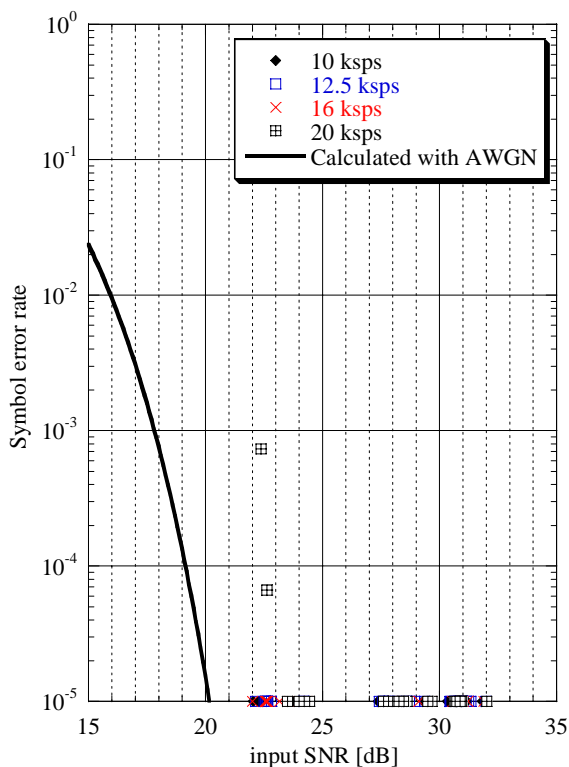

Figure 11: Symbol error rate vs. input SNR.

5 Summary

The wideband conical beam transducer was developed. The sea trial was carried out using that transducer. At the range of 90 m, communication was carried out that the transmission rate of 20 ksps (80 kbps).

In case of full power transmission, the input SNR was approximately 30 dB. From this result, it is estimated that the transmission range would extend to 300 m. As the next experiment, data of around 20 dB of input SNR would be measured.

As the future work, we will develop more effective phase compensator, and we will execute sea trials in more difficult conditions.

References

- [1] M. Stojanovic, 'Recent Advances in High-Speed Underwater Acoustics Communications', *IEEE Journal of Oceanic Engineering*, Vol. 21, No. 2, pp. 125-136 (1996).
- [2] D. B. Kilfoyle and B. Baggeroer, 'The State of the Art in Underwater Acoustic Telemetry', *IEEE Journal of Oceanic Engineering*, Vol. 25, No. 1, pp. 4-27 (2000).
- [3] H. Ochi, T. Tsuchiya, et al., 'Study on colour video pictures transmission by digital acoustic signal', Proc. PORSEC-'92, Okinawa, pp. 132-137 (1992).
- [4] H. Ochi, T. Shimura, et al., 'Underwater acoustic data transmission system for AUV "URASHIMA"', Proc. International Society of Offshore and Polar Engineering, pp. 674-679 (2004).
- [5] M. Stojanovic, et al., 'Adaptive multichannel combining and equalization for underwater acoustic communications', *Journal of Acoustical Society of America*, Vol. 94, pp.1621-1631 (1993).